



DELTA-XERO

THE FUTURE IS SYSTEM RELIABILITY

DX1001-W

The DX modular housing arrangement offers a flexible and space conscious solution to integrate our innovative DXO Cartridge in to both new and existing systems. The Delta-Xero system can be configured up to 3 cartridges in parallel as a single unit in a compact and easily maintainable layout.

The unit can be supplied with a number of standard options to provide an effective fluid conditioning and monitoring package to suit the majority of systems. The flexibility of the unit allows tailoring to customer's specific requirements.



DX1001-W

Drive Input	Electric or Pneumatic
Connection Ports	3/8" BSP In & Out
Flow Indicator	Visual
Suggested System Volume	Up to 4500ltrs @ 32cSt
Particulate Removal	From 0,1 µ
Weight	15 kg
Measure	H 524 mm x D 261 mm x L 442 mm
Material	SS316
DXO Cartridge QTY	1

Flow Rate varies depending on viscosity, pressure and temperature

Approx flow at 2.7 bar:	32 cSt	46 cSt	68 cSt	100 cSt	220 cSt	320 cSt	460 cSt
Oil Volume	125 l/min	10 l/min	0.8 l/min	0.6 l/min	0.4 l/min	0.2 l/min	0.1 l/min
	4500ltrs	3500ltrs	3000ltrs	2400ltrs	1800ltrs	800ltrs	400ltrs

General Arrangement + Schematic

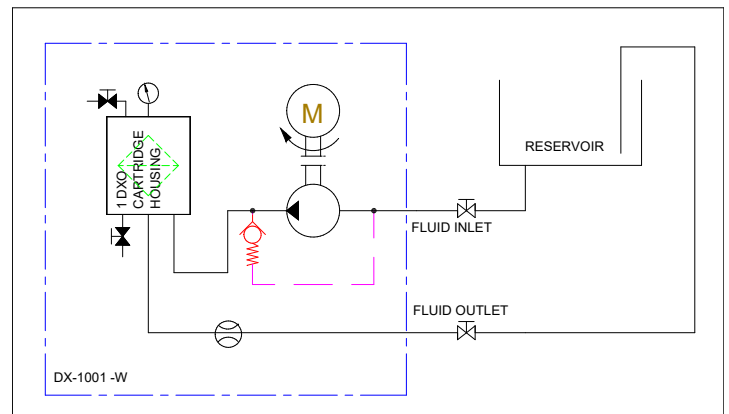
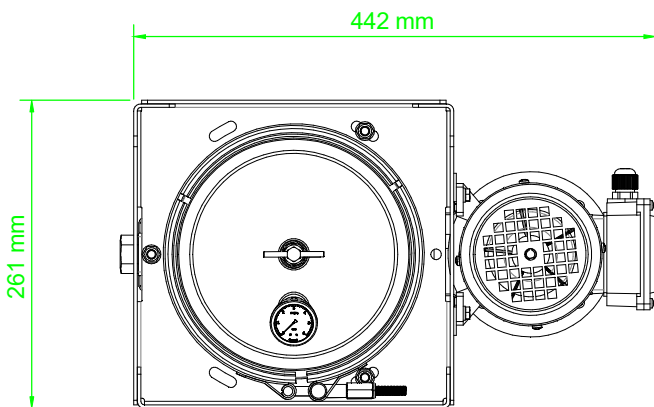
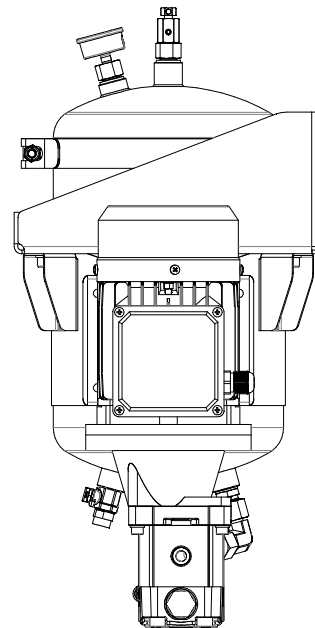
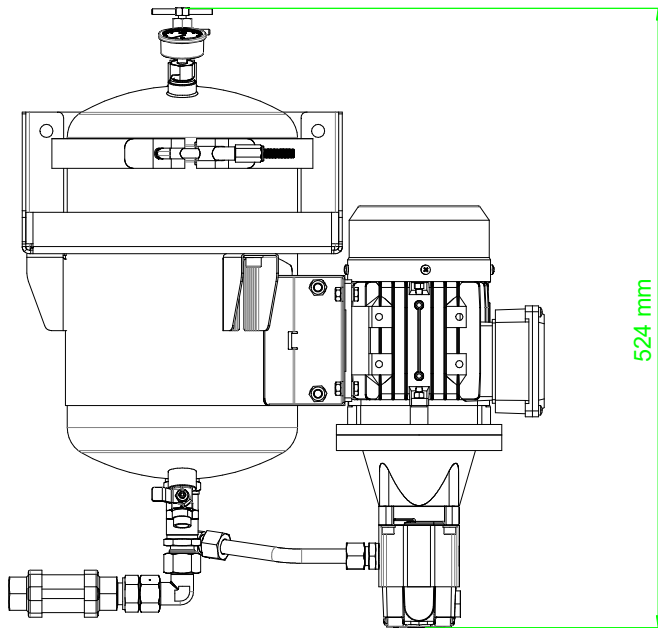

Cartridge Data: DXO

Contaminated weight:	Up to 4.5kg per DXO
Water holding capacity, free and bound:	Approx. 2600ml
Material insert:	PP Cellulose mix

