

FM025 Centrifuge

Technical Data



BENEFITS

- Cleaner oil and extended oil life
- Lengthens service intervals
- Reduces engine wear
- Enhances long-term preventative maintenance
- Reduces maintenance costs
- Cuts waste disposal costs
- Reduces application down time
- Maximises in-service time for vehicle/engine/machine
- Reduces total cost of ownership
- Helps ensure clean combustion and fuel efficiency
- Supports engine technology for the reduction of exhaust emissions (e.g. exhaust gas recirculation)
- Fast return on investment

DIMENSIONS (mm)

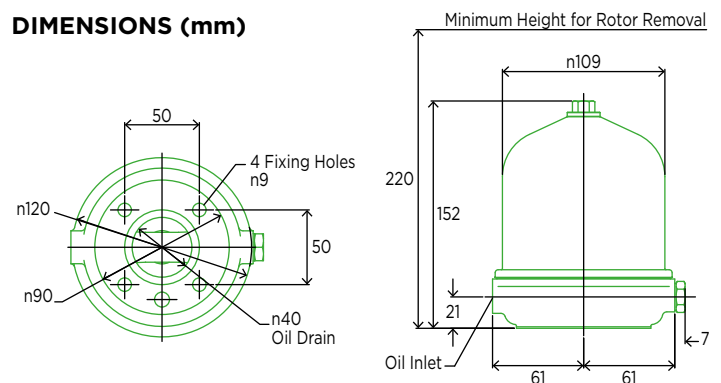

Model	FM025-4
Part number	6899111701
Oil inlet thread	Side 1/4" B.S.P.
Cut Off Valve (C.O.V.) ratings	1.3 bar
Net weight	1.4 kg
System capacity	5 - 15 litres for lubrication system
Filter dirt capacity	0.25 litres
Filter oil capacity	0.32 litres
Minimum oil feed pipe size	Ø 6 mm internal
Minimum oil drain pipe size	Ø 25 mm internal
Rotor	Cleanable

PERFORMANCE CURVES

Typical Rotor Performance

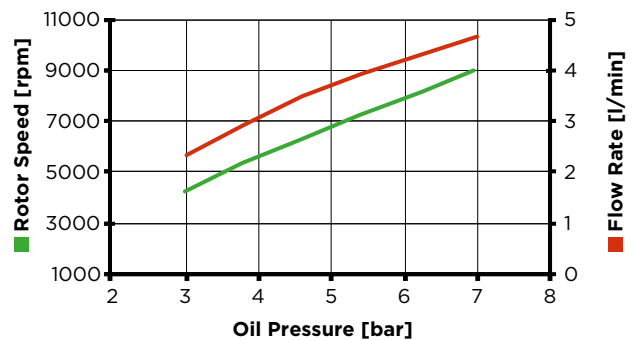

Authorised Distributor



t: +44 1264 860 186
e: spares@simplexturbulo.com



Simplex-Turbulo is part of the **SLX** GROUP

Leadership in Filtration

**MANN+
HUMMEL**