



DX1525

The DX1525 system has been designed to be our most compact and cost effective fluid conditioning unit on offer.

Engineered to fill a gap in our product offerings for smaller volume systems the DX1525 is ideal for keeping fluid in reservoirs below 1000 liters in optimum health,

With budgets for maintenance ever decreasing Delta-Xero wanted to ensure that all market segments like plastic extrusion or the wind turbine industry could easily and cost effectively reduce their carbon foot print.

The DX1525 can also be supplied with a number of options to provide an effective fluid conditioning and monitoring package to suit the majority of systems.

These units come both floor and wall mountable.



DX1525

Drive Input	Electric
Connection Ports	3/8" BSP In & Out
Flow Indicator	Visual
Suggested System Volume	Up to 1000l @ 32cSt
Flow Rate	0.5 lpm @ 32cSt
Particulate Removal	From 0.1 μ
Weight	13 kg
Dimensions	H 362 mm x D 216 mm x L 380 mm
Material	SS304, 316 and Aluminum
DXO-1525 Cartridge QTY	1

© 2021 Delta-Xero All Rights Reserved. All information contained in this publication is indicative only and may be subject to change without prior notice.



General Arrangement + Schematic

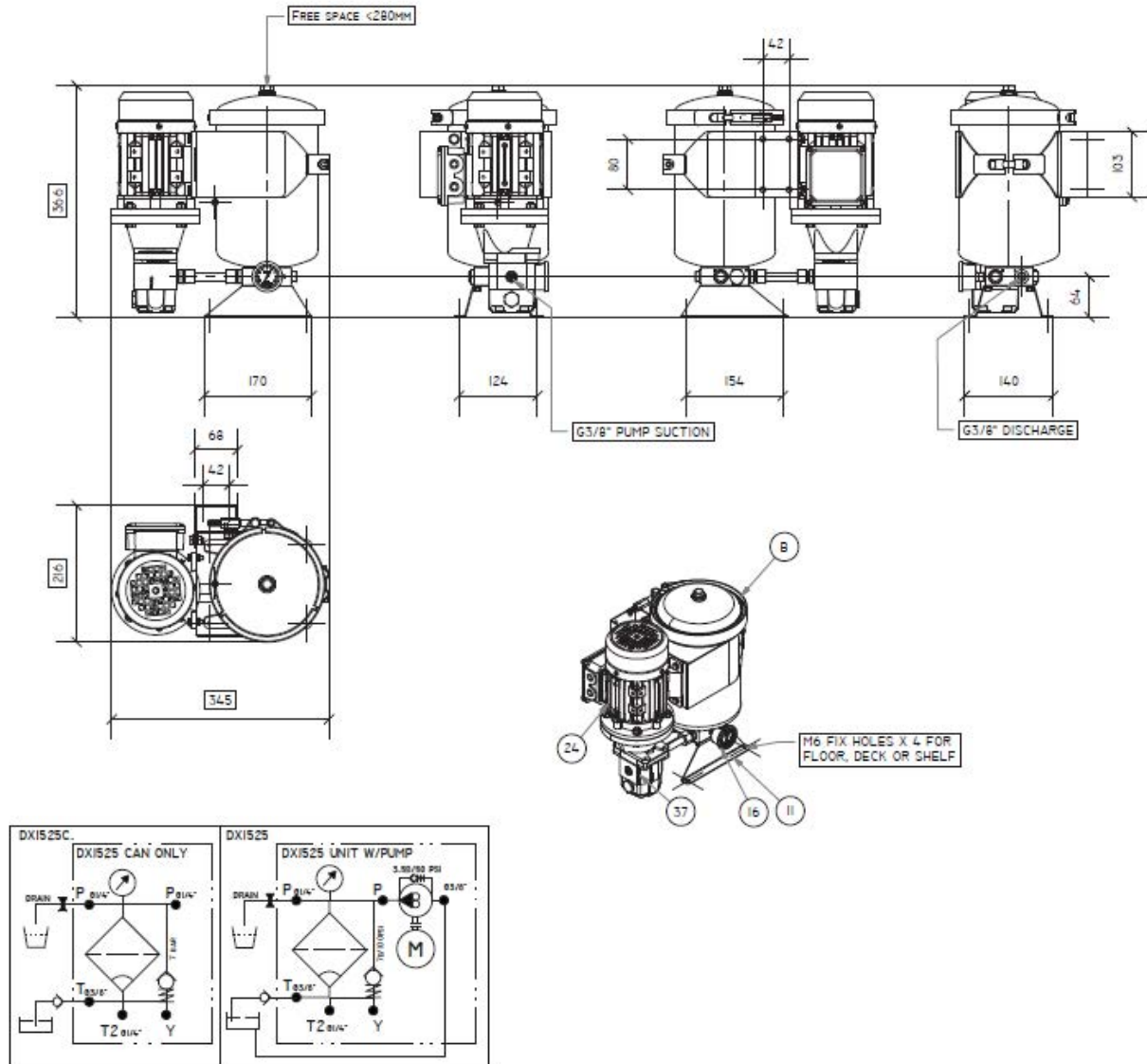

Cartridge Data: DXO-1525

Contaminated weight:	Up to 2.6kgs per DXO-1525
Water holding capacity, free and bound:	Approx. 800ml
Material insert:	PP Cellulose mix

